

# THERMALLY MODIFIED REAL WOOD CLADDING BOARDS AND SHINGLES

2025/2026 standard and  
made-to-order assortments

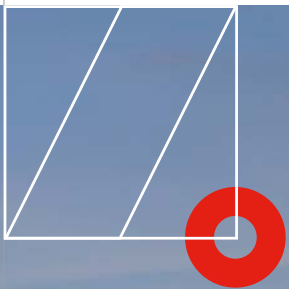

# We are Thermory

We create real wood solutions for a valuable and sustainable living environment

---

THERMORY is a world leader in the thermal modification of wood. We offer high-quality, long-lasting solutions that benefit from environmentally friendly technology. We have spent the past two decades developing our expertise through close collaborations with architects, designers, builders and homeowners – constantly revising our product selection and refining our technology in the process.



THERMORY.COM

## Why Thermory?

### THE ORIGINAL AND THE BEST

As a pioneer in thermally modified dense hardwoods and woods with third-party verified durability, Thermory's highly qualified and deeply experienced experts use our own kilns, controlling the entire process to deliver products renowned for their consistent durability, stability, quality and usability.

### SOURCING EXCELLENCE

Our strict criteria and long-term partnerships with top forestry companies ensure a consistent supply of superior lumber in high-end species like ash, oak, radiata pine, spruce and pine. 98% of our softwood is FSC or PEFC certified, with ISO and Nordic Swan Ecolabel certification also available.

### SMOOTH, STRAIGHT, DURABLE WOOD

Thermory's advanced thermal modification technology makes our wood durable to the core for its entire lifetime – and thanks to our smooth planing and precision techniques, our wood has exceptionally smooth surfaces and bends significantly less than alternative products.

### EASY INSTALLATION

Thermory cladding is light, stable and easy to install. Our smart installation solutions like hidden fixings and end-matching make our products effortless to use.

### LESS WASTE, LESS HARM

With Thermory end-matched cladding you can save up to 10–15% of material. Our naturally durable, chemical-free, non-toxic wood is also safe to process, discard and re-use.

### IDEAL FOR ANY DESIGN

Our wide product selection, beautiful designs and high-end finishing ensure limitless options for any project. And as a chemical-free, organic building material with durability, sustainability and natural aesthetics, Thermory wood is perfect for biophilic designs incorporating natural features and elements.





Ormsõ Beach House, Estonia. Thermory Vivid Opaque thermo-spruce, C15 black, brushed. Photo: Maksim Tund.



Private Time house, Estonia. Thermory thermo-ash cladding and pine decking. Photo: Krõõt Tarkmeel.



# Thermal modification

We naturally enhance wood using only heat and steam

Unlike chemical impregnation, thermal modification enhances the wood throughout, not just the outer surface. The result is boards that are stable and durable in every sense.

The thermal modification process takes place in a heating chamber with special sensors, controlled by experienced specialists using computers.

Thermory's quality is ensured by a special thermal modification process developed through 25 years of experience, which is adapted according to the wood species and purpose of use.

The principle is the same: the moisture level of the wood is reduced over a period of 36–72 hours and then the temperature is raised to the necessary level, followed by cooling and misting.

At all times during the thermal modification process, only temperature changes and steam are used. Heat triggers physical and chemical reactions in the wood, and the process is controlled by adjusting the moisture level.

## Modified wood benefits



**HIGH DURABILITY**

Thermal modification gives wood the highest durability class



**STABLE**

Thermally modified wood is more dimensionally stable in changing weather conditions



**BETTER INSULATING QUALITIES**

The boards do not become as hot in the sun



**SUSTAINABLE**

Thermal modification is a chemical-free treatment



**LIGHTER MATERIAL**

The wood's lower moisture content makes it lighter



**SAFE WASTE HANDLING**

Thermory wood doesn't need to be handled as hazardous waste

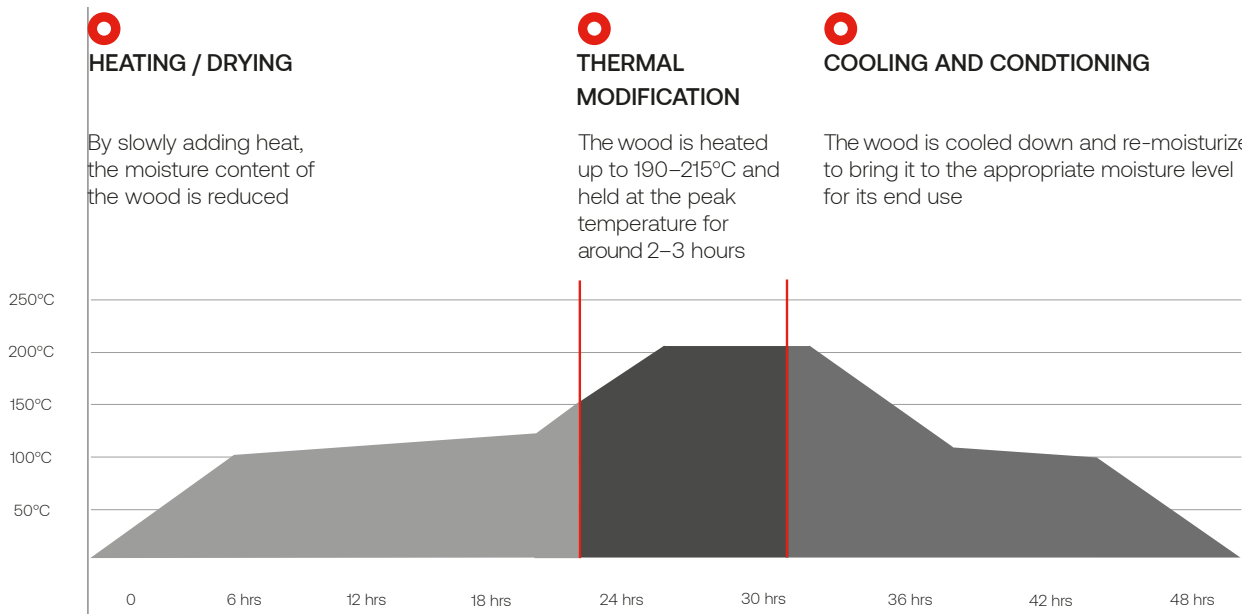



Thermo-kilns at our Loo production facility

## Our wood comes from sustainably managed forests

Thermory promotes a transparent and responsible corporate culture. We care about the environment and treat nature with deep respect. Our purchasing process

is environmentally responsible, and we exercise high standards for quality and sustainability. All Thermory wood goes through very strict quality control.

### Declaration of Performance (DoP) and CE marking

The declaration of Performance gives information about product quality, and the CE label assures customers that products conform with the EN 14915 standard.



### Programme for the Endorsement of Forest Certification (PEFC)

Most of our softwood comes from PEFC-certified forestry. PEFC is a worldwide federation of national forest certification systems.



### Forest Stewardship Council® (FSC®)

As a pioneer of forest certification, the FSC has 25 years' experience in sustainable forest management. The FSC is the major advocate for better forest management.



### Our products' durability has been tested by CATAS

CATAS is one of the largest testing and applied research laboratories in Europe.



### Environmental Product Declaration (EPD)

The Environmental Product Declaration is a document that provides transparent information about the environmental impact of any product or material during its lifetime.



### Fire-retardant wood

Selected species of Thermory thermally modified wood are now available with fire-retardant properties, in collaboration with Woodsafe Timber Protection. Improve your Thermory cladding with durable fire protection.

### WOODSAFE®

READ MORE ABOUT CERTIFICATIONS AND TESTING



# Thermory wood species for cladding

Thermory offers natural and thermally modified real wood products in a wide range of profiles and dimensions.

## THERMO-ASH

### A HIGH-PERFORMANCE HARDWOOD THAT EXCEEDS EXPECTATIONS

Thermory's thermally modified ash products are a hardwood solution offering exceptional rot resistance and longevity combined with a clear face and a rich brown color.

COLLECTIONS: Benchmark, Vivid Oiled



## THERMO-SPRUCE

### A DURABLE SOFTWOOD WITH RUSTIC CHARM

Spruce, sourced in Scandinavia and thermally modified by Thermory, offers a softwood solution with exceptional rot resistance and longevity combined with rustic knots and a naturally light golden-brown color.

COLLECTIONS: Benchmark, Kodiak, Stripes, Ignite, Vivid



## THERMO-PINE

### THE NEW DURABILITY STANDARD FOR SOFTWOOD

The natural look of thermally modified pine is golden-brown, with distinctive knots and more resin than other woods. Thermal modification adds decades of rot resistance to this softwood without using any chemicals.

COLLECTIONS: Benchmark, Vivid, Stripes

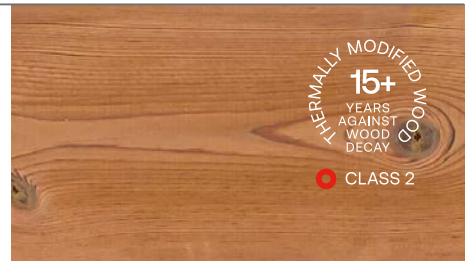

## THERMO-RADIATA PINE

### AN ELEGANT, KNOT-FREE LOOK IN DURABLE SOFTWOOD

The natural color of thermally modified radiata pine is a warm caramel brown. Each and every board is unique, with its own natural grain pattern.

COLLECTIONS: Benchmark, Stripes

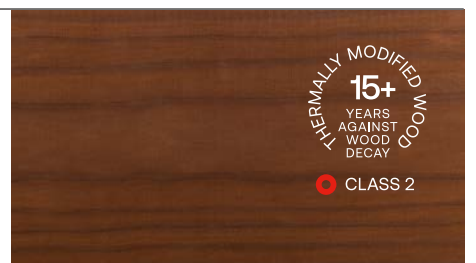

## THERMO-OAK

### AN EXCLUSIVE HARDWOOD WITH INHERENT BEAUTY AND SOPHISTICATION

This attractive reddish-brown cladding is designed for those seeking nothing less than the best in quality and style. Thermo-oak features the same superior durability as thermo-ash.

COLLECTIONS: Benchmark, Vivid Oiled

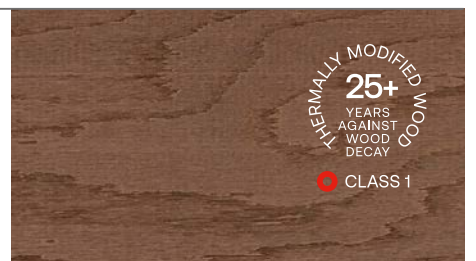

READ MORE ABOUT THE GRADING RULES FOR EACH WOOD SPECIES





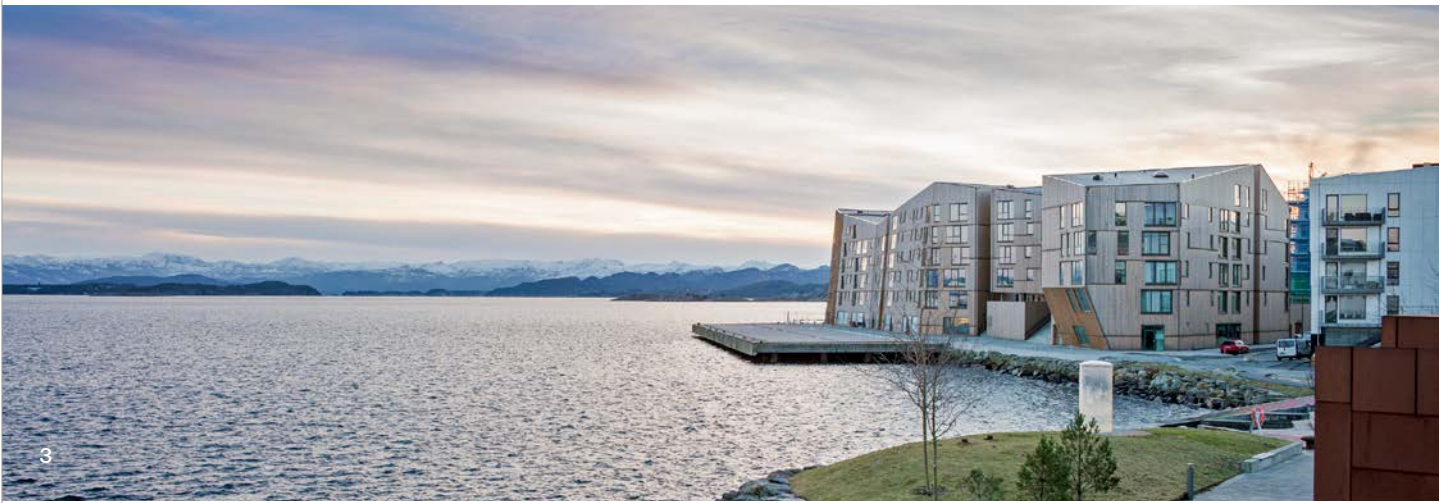

1. Pelgulinna State Upper Secondary School, Estonia. Thermory thermo-pine cladding and glued posts, with fire protection by Woodsafe WFX. Architect: Arhitekt Must. Photo: Tõnu Tunnel.
2. Paide State High School, Estonia. Thermory Benchmark thermo-pine cladding. Photo: Tõnu Tunnel.
3. Vannkanten (The Waterfront) residential development, Stavanger, Norway. Thermory Benchmark thermo-pine decking, cladding and roofing. Architect: AART Architects.
4. Rakvere State High School, Estonia. Thermory pine cladding, C4. Photo: Karl Kasepõld.
5. Centro Arte Moderna Gulbenkian, Lisbon, Portugal. Thermory thermo-ash. Architect: Kengo Kuma & Associates. Photo: Fernando Guerra.

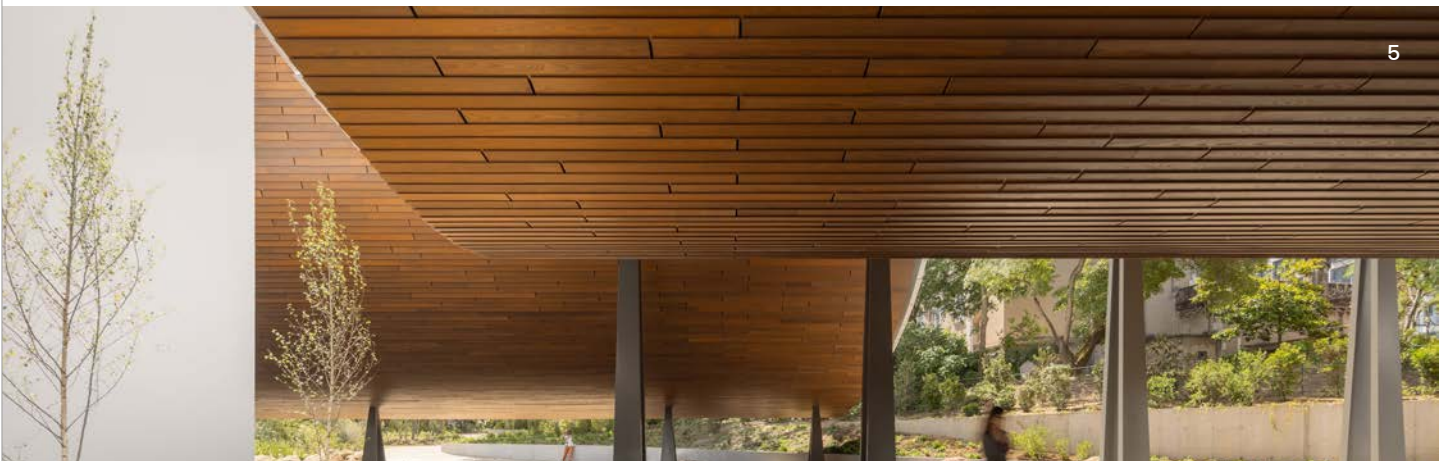



# Wood surface treatments

Real wood is a uniquely charismatic and beautifully textured material that carries a strong aesthetic message. In addition to our wide range of wood species and styles, Thermory offers a selection of

surface treatment solutions to either enhance this natural beauty or make the wood more durable and suitable for various purposes and weather conditions.

## Coating and oiling

Thermory offers a wide range of coated and oiled cladding products that enhance both durability and aesthetics. Our coated cladding undergoes thermal modification for stability and is finished with eco-friendly, long-lasting paints, while UV-resistant oils help preserve or adjust the wood's color over time. Read more about our coated collections starting on pages 12–14: Vivid Opaque, Vivid Translucent, Vivid Silvered, Vivid Oiled, Ignite, and Stripes.

**Featured in collections:** Vivid Opaque, Vivid Translucent, Vivid Silvered, Vivid Oiled, Ignite, Stripes

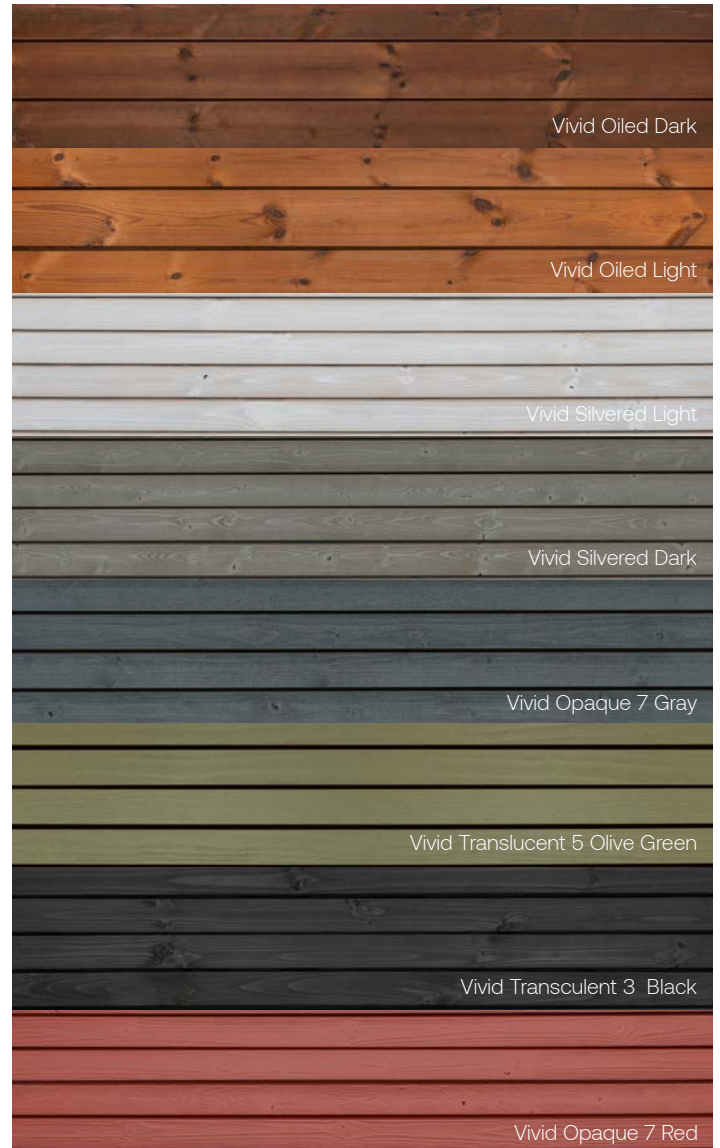

## Brushing

Brushing gives the wood's surface a unique appearance, removing and beautifully highlighting some softer parts of the surface.

**Featured in collections:** Kodiak, Benchmark





## Embossing

Embossing is a chemical-free process that creates a decorative raised or recessed pattern to add texture and visual interest to the wood's surface.

Featured in collections: Ignite, Dune



## Roughening

Roughening creates a sawn surface, giving the boards a distinctive rustic appearance with refined furrows. This process can be applied for both functional and aesthetic purposes.

Featured in collections: Benchmark, Vivid



## Fire protection

Fire protection solutions are offered with Thermory's thermally modified selected wood species in cooperation with Woodsafe Timber Protection.

This unique technology alters the wood's natural properties when it's exposed to fire, ensuring it adheres to the strictest requirements for combustible materials.

# WOODSAFE®



Pelgulinna State Upper Secondary School, Estonia. Thermory thermo-pine cladding and glued posts, with fire protection by Woodsafe WFX. Architect: Arhitekt Must. Photo: Tõnu Tunnel.

READ MORE ABOUT  
FIRE PROTECTION





# Cladding collections

## Benchmark



### Thermally modified natural wood

Timeless, functional, durable and environmentally friendly – that's exactly what our Benchmark Series is all about.

Each board is thermally modified, resulting in naturally beautiful and environmentally friendly products that last for generations.

Depending on the profile, Benchmark timber cladding can be installed with screws, clips or PaCS – the world's simplest screwless system.

Most profiles can be ordered with an end-matching solution, meaning that the joints don't have to rest on joists – this reduces wastage, labor costs and installation time.



READ MORE ABOUT  
BENCHMARK SERIE





## Kodiak



### Big, bold and rugged thermo-spruce

Thermory's Kodiak range can be used for a particularly rugged and natural atmosphere, with its extra-wide boards creating a stylish, modern look and feel.

Its sturdy boards, with their brushed texture, are inspired by the majestic Kodiak brown bear and represent the harsh, wild charm of the Alaskan forests, its natural habitat.

The spruce and pine products undergo an intense thermal modification process that uses only heat and steam to give exceptional stability and durability.



Private residence, José Ignacio, Uruguay. Thermory Kodiak thermo-spruce cladding, C15 and decking D4. Photo: Maximiliano Vila.

READ MORE ABOUT KODIAK



## Shingles



### Add texture to your interior or exterior walls!

Shingles by Thermory, with their resawn surface, are a trendy way to add texture to your interior or exterior walls. Intense thermal modification increases the panels' dimensional stability and durability while bringing out the wood's natural beauty.

Thermory Shingles are especially environmentally friendly since they are produced from cut-offs, that would otherwise end up as wood waste.

Like all Thermory products, the shingles will naturally gray over time, bringing a uniquely elegant tone to your design.

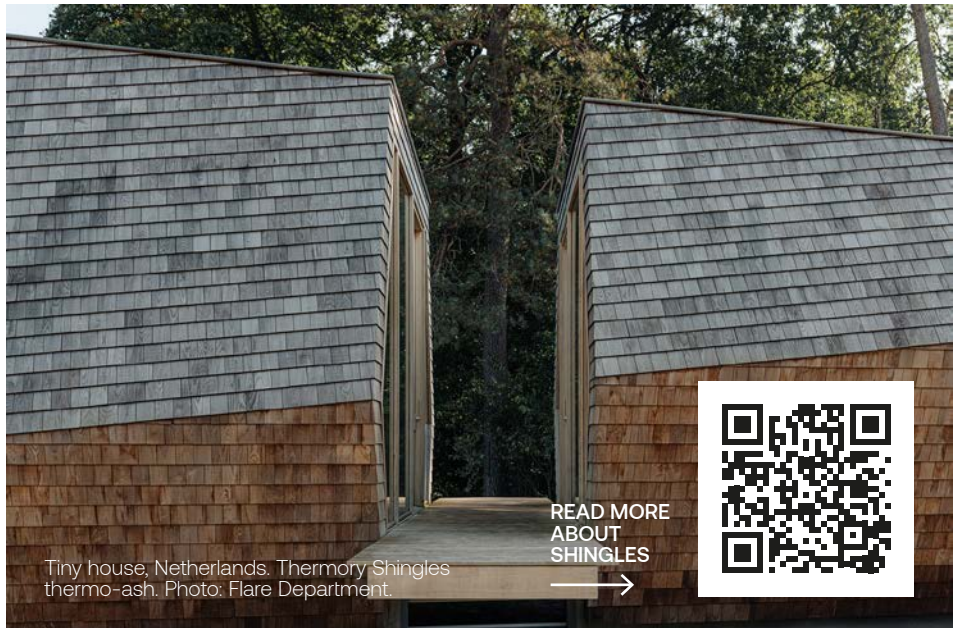

Tiny house, Netherlands. Thermory Shingles thermo-ash. Photo: Flare Department.

READ MORE ABOUT SHINGLES

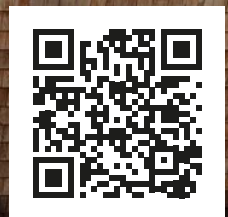



# Stripes



## Ribbed cladding that's a breeze to install

Thermory's Stripes series gives your walls a stylish open look, with closed-jointed cladding that offers easy installation and weather protection.

This unique wood cladding series for interior and exterior use cleverly mimics the appearance of open-jointed cladding thanks to painted black stripes in the cladding grooves. Stripes by Thermory is available with a choice of profiles and wood species.

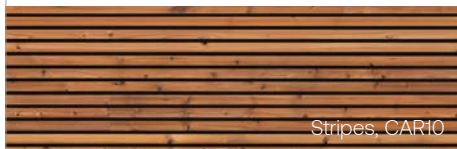

Stripes\_CAR10

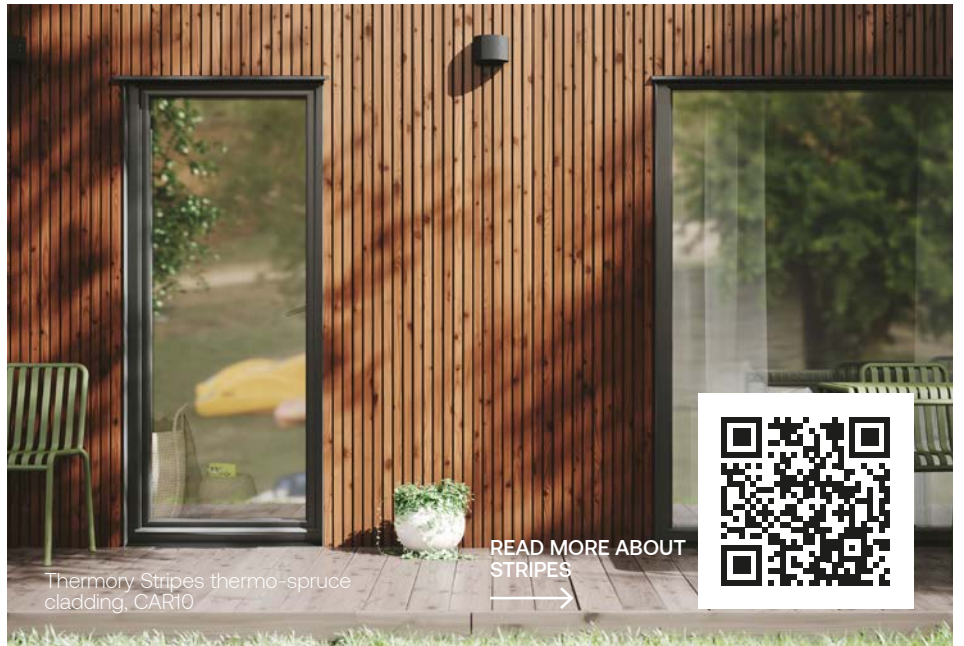

Thermory Stripes thermo-spruce cladding, CAR10

READ MORE ABOUT STRIPES



# Ignite



## An ancient cladding tradition with reliably modern performance

Hundreds of years ago, Japanese woodworkers discovered that they could prolong the life of wood by charring its exposed surface – this process, called yakisugi, created enviable, stunning results that are still in high demand today.

Thermory Ignite cladding provides the same appealing look with durability all the way through to the core. And unlike charred wood, Ignite doesn't have the issue of messy residue.



ignite

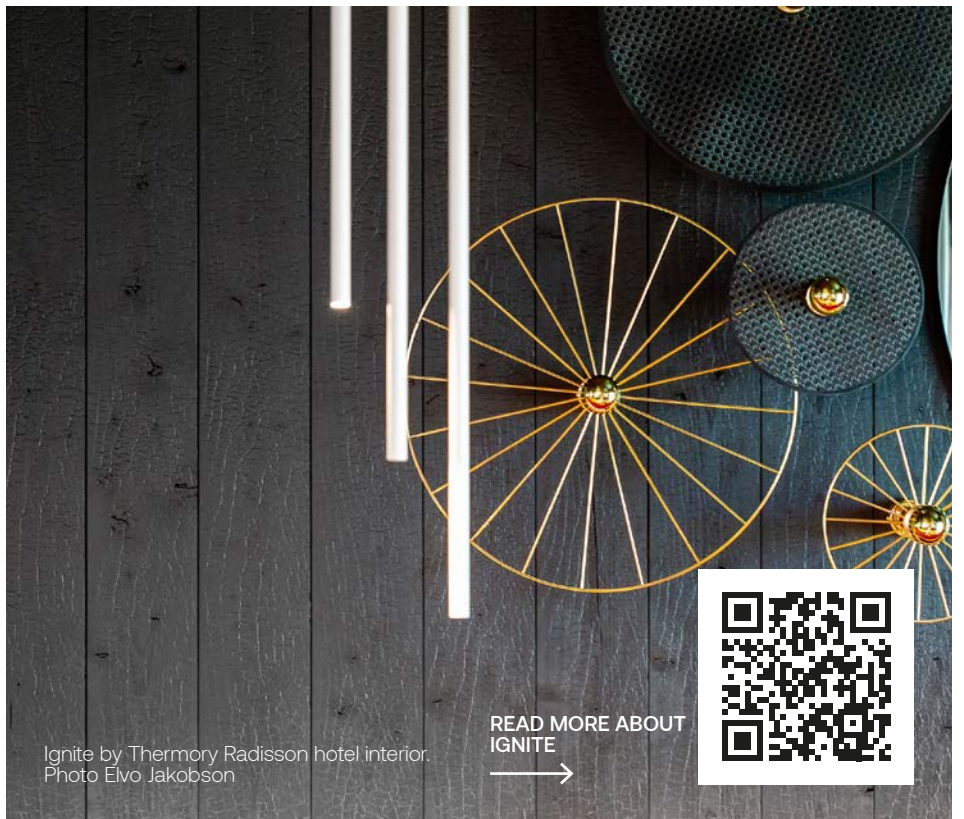

Ignite by Thermory Radisson hotel interior. Photo Elvo Jakobson

READ MORE ABOUT IGNITE

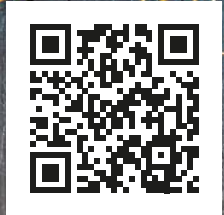





# Vivid Silvered

### An evenly weathered look that lasts for decades

With our Vivid Silvered family of products, we've uncovered a solution for a completely even gray façade right from the day of installation. Enjoy a uniformly pre-weathered look that lasts for decades and doesn't require any maintenance coating – just cleaning every few years.

The thermally modified boards are coated with just the right amount of gray color; over time, the wood becomes visible in a pleasing way as the paint coating gradually wears off, eventually revealing the natural gray tone of the wood.



Vivid Silvered Dark  
(thermo-spruce, brushed)



Vivid Silvered Light  
(thermo-pine, brushed)



Vivid Silvered Sand Gray  
(thermo-spruce, roughened)



Vivid Silvered Shield  
(thermo-pine)



Thermory Vivid Silvered and Vivid Translucent cladding. Architect: KUU Arhitektid. Developer: Invego. Photo: Karl Kasepõld



READ MORE ABOUT VIVID SILVERED



# Vivid Opaque



### Vivid Opaque coated cladding – go wild with your walls!

Vivid Opaque is thermally modified cladding, coated with opaque (non-transparent) water-based paint. Depending on the local climate, the maintenance interval for Vivid Opaque products is 7–10 years. Simply select your preferred color and profile to create a cladding solution with its own unique appeal.



Vivid Opaque 7 Gray  
(thermo-spruce, roughened)



Vivid Opaque 7 Red  
(thermo-pine, brushed)



Vivid Opaque 7 Black  
(thermo-spruce, brushed)

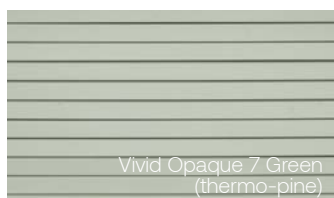

Vivid Opaque 7 Green  
(thermo-pine)



Private house, Estonia. Thermory Vivid thermo-pine cladding, mix and match C34, brushed and painted. Photo: Terje Ugandi



READ MORE ABOUT VIVID OPAQUE





# Vivid Translucent

Sophisticated cladding with the natural look of exposed timber

Vivid Translucent cladding boards are thermally modified for enhanced durability and stability, then coated with a translucent color so the wood's beautiful natural pattern shines through. Depending on the climate and the chosen color, the maintenance interval for Vivid Translucent 3 products is 2-3 years and Vivid Translucent 5 products 5-7 years.



Vivid Translucent 3 Black (thermo-pine)



Vivid Translucent 3 Thermo Brown (thermo-spruce, brushed)

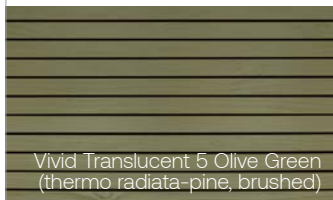

Vivid Translucent 5 Olive Green (thermo radiata-pine, brushed)



Vivid Translucent 5 Thermo Brown (thermo radiata-pine, brushed)



# Vivid Oiled



Durable cladding boards with a protective oil coating

Vivid Oiled cladding comes in ash, oak or a selection of other wood species and is coated with oil to either preserve or enhance the wood's beautiful look.

With our Light or Dark oiled cladding, the wood is protected from turning silver-gray when exposed to UV light over time, while our Gray and Black toned oil options allow you to give the material an appealing new look.



Vivid Oiled Black (thermo-ash)



Vivid Oiled Dark (thermo-ash)

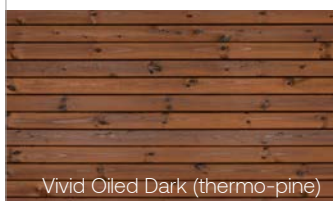

Vivid Oiled Dark (thermo-pine)



Vivid Oiled Light (thermo-pine)





# Installation methods

Functional and easy-to-implement hidden installation systems by Grad®



## Cladding and decking installation with just a press and a click!

The Grad® x Thermory® partnership combines high-quality Thermory thermally modified wood with the unique Grad installation system. Thermory's line for Grad consists of

specially profiled Thermory boards with grooves on the underside to perfectly fit the Grad clips. As a result, there are no visible screw heads – the boards are simply pressed and clicked into place.



The boards click into place when depressed and it's done.

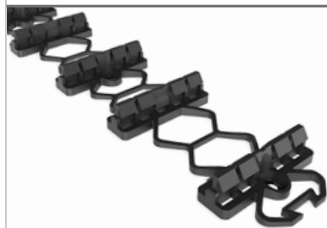

**GRAD® Strip** is a fastening solution for GRAD® cladding and decking. Grad® Strip is a six-clip strip that fixes three boards (board width 118mm) onto one batten/joist. These strips must be connected together and fixed to the batten/joist, and the boards can then be easily snapped onto the clips. The strip will leave a 5 mm gap between the boards, and the clip thickness raises the board 5 mm above the batten/joist to prevent wood-to-wood contact and ensure the required ventilation.



**GRAD® Alu Rail Start** is a non-load-bearing aluminum joist with pre-mounted GRAD® clips that can be mounted on a flat surface or wooden battens. It raises the boards 18 mm (rail 12 mm + Grad® clips 6 mm), ensuring the required ventilation. Special keys are available for removing the boards. This is the most suitable fastener for small projects with custom clip spacing.



**EASY INSTALLATION**  
Just press and click



**HIDDEN FIXING**  
No visible screws

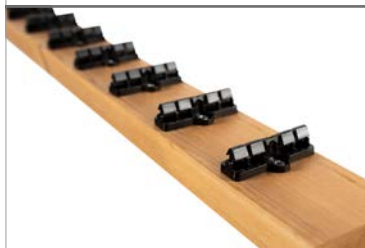

**PaCS® CLAD** consists of a Thermory thermo-pine batten with pre-mounted Grad® single clips. Clip spacing can be customized according to the project.



**Grad single clip** can be used with all profiles. This is the most suitable fastener for small projects with custom clip spacing.

## T-4 and T-6 clips

Thermory black-coated stainless-steel T-4 and T-6 clips both create a cladding surface with no visible screws. The T-4 clip leaves a 4 mm gap between the boards, and T-6 leaves a 6 mm gap. Stainless-steel screws are included with the clips.

**ESTIMATED NUMBER OF T-4 OR T-6 CLIP FIXINGS REQUIRED:**  
2 clips per running meter of cladding board (if the distance between the battens is 600 mm)

**CLIPS PER WHOLESALE PACKAGE:**  
500, screws and drill bit included

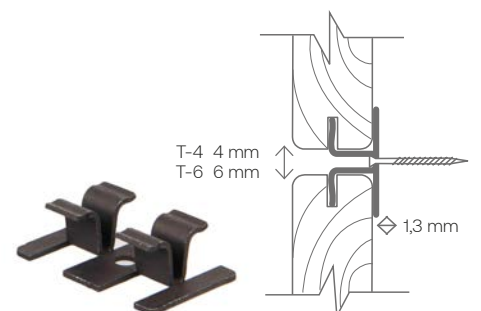

# B1-1 clip

Thermory's stainless steel B1-1 clip creates a cladding surface with no visible screws. Use 4 x 40 mm stainless steel screws to fix the clips to the batten; we recommend two screws per clip.

**ESTIMATED NUMBER OF B1-1 CLIP FIXINGS REQUIRED:**

2 clips per running meter of cladding board (if the distance between the battens is 600 mm)

**CLIPS PER WHOLESALE PACKAGE:**

100

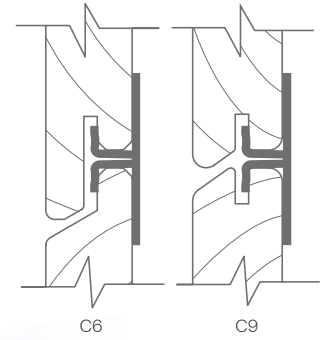

# Stainless steel screws, nails or staples

Thermory thermally modified wood must be fixed with stainless steel fasteners (A2 or A4).

For Thermory thermo-ash cladding, pilot holes should be predrilled. The pilot holes should be equal in diameter to the screw's nominal diameter to allow for any necessary board movement and prevent shear stress on the screws.

Thermory thermo-pine, thermo-spruce and thermo-radiata pine cladding can be fixed with self-tapping screws, nails or staples. Be sure to set the power drill's clutch or adjust the nail gun/staple gun firing depth so that the head of the fasteners are sitting flush with the surface of the board when fixed.

For further fastening suggestions, please read the Thermory cladding installation guide.

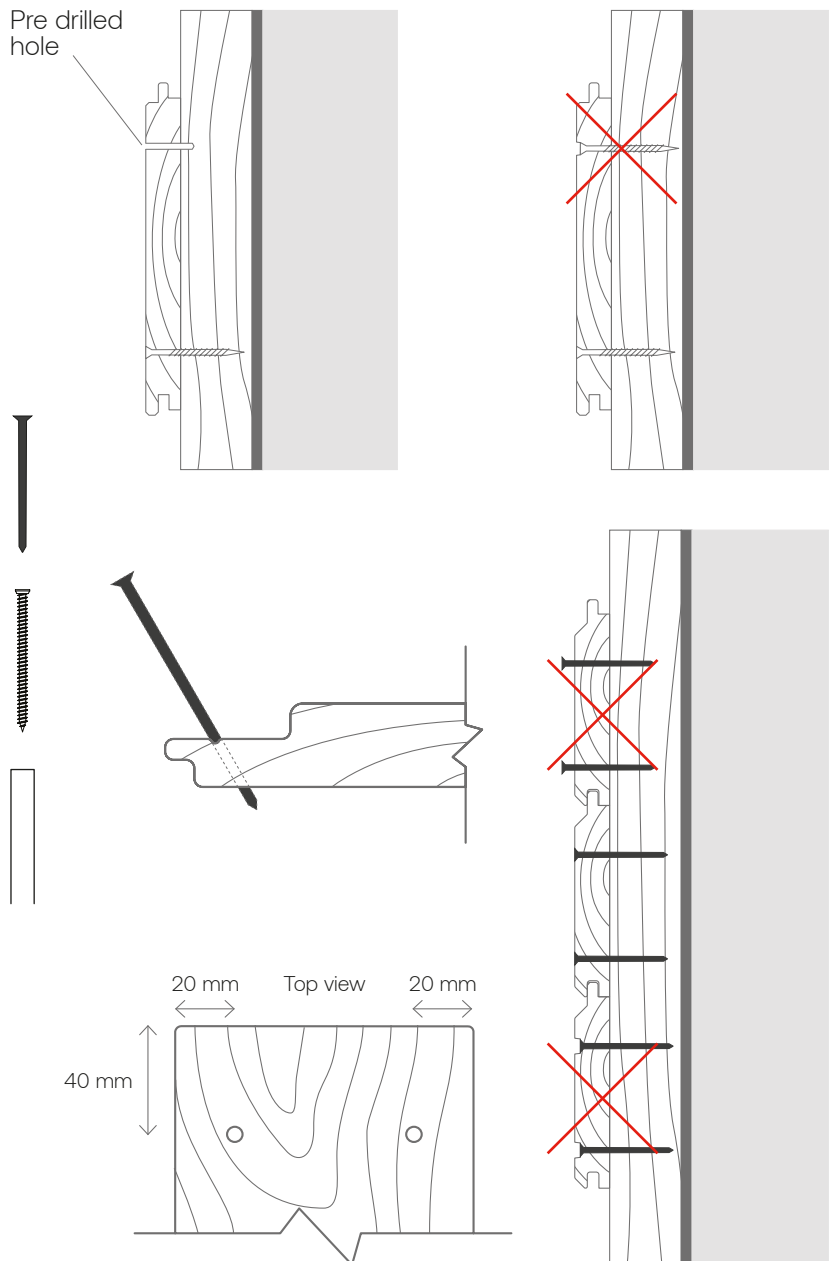



# Useful tips

## Save money and wood by using shorter boards

Did you know that shorter cladding boards, like 1.5 meter boards, are always a little cheaper than longer ones?

By calculating your exact needs for cladding boards and using shorter ones where possible, for example in the construction of bases for roof eaves or continuation places above and below windows, you can use shorter boards in a pleasing way while also saving money.



## Mix & Match!

Our Mix & Match cladding profiles are designed to let you play around with the available combinations to create your own perfect design.

The profiles are available in a large variety of widths and depths, and our C34 cladding profiles can also be distinguished further with a surface coating, as in our Vivid collection.

GET  
INSPIRED!  
→

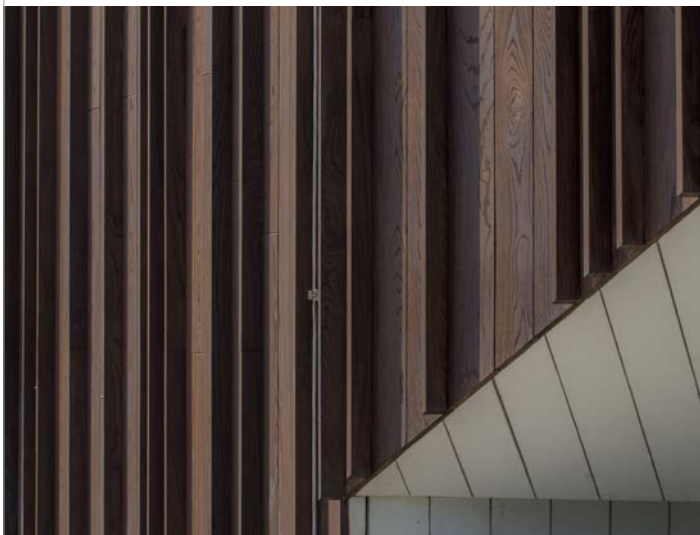
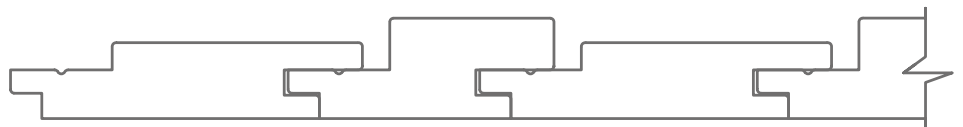



## Reduce waste and save installation time with end-matched cladding boards

With an end-matched board you need **11% less material!**

For a tight and clean look, most Thermory® profiles can be produced with end-matching, which enables falling lengths to be installed efficiently. In addition to the beautiful, clean design aesthetic, it also saves time measuring and cutting!

With Thermory's exclusive end-matching, the ends of the boards do not need to rest on the support joists. This creates less waste, reducing labor costs and shortening the installation time. Each board must rest on and be fastened to a minimum of two joists.

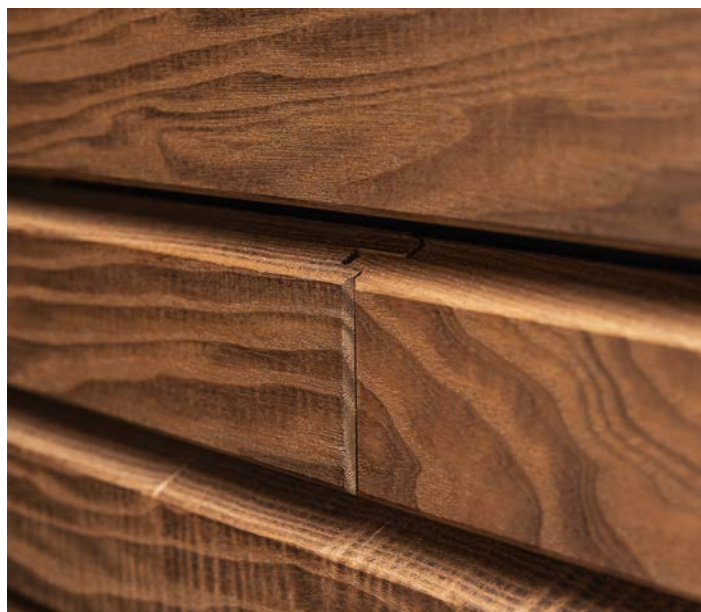
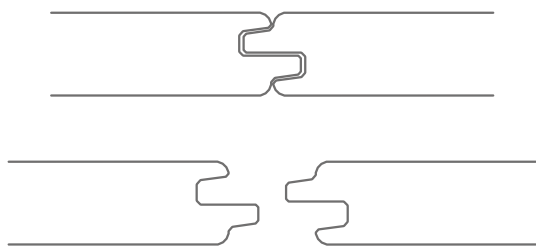

Thermory thermo-ash cladding, C7J, with end-matching.



Thermory thermo-ash decking, D45J, with end-matching.



Private house, Saaremaa, Estonia. Thermory thermo-ash cladding, C20, with end-matching. Photo: Elvo Jakobson.



# Prolonging the service life of your cladding

The correct installation and maintenance practices are important for beautiful, long-lasting cladding. Please follow the requirements in Thermory's cladding installation and cladding maintenance guides, and remember that wood is a

natural material that will always react to external conditions. Properly stored, installed and maintained cladding will withstand your local weather conditions better.

## STORAGE AND WAREHOUSING

Whenever possible, cladding boards should be stored inside, protected from sunlight and water. If kept outside, the boards should be elevated at least 150 mm from the ground, stacked evenly and protected with a waterproof, light-impermeable cover. Leave the ends of the cover unfastened to provide ventilation.

For a few weeks prior to installation, store the boards at the installation site to allow them to acclimatize to the moisture conditions there, using a protective cover to protect them from rain.

Handle Thermory boards with care. The tongue-and-groove sections of boards may be fragile.

## INSTALLATION

When installing Thermory cladding, always use stainless steel nails, staples or screws, or Thermory fastening clips.

Boards with a tongue and groove must be installed with the tongues pointing

upwards. In vertical applications, the tongues should point in the direction that the wind most commonly blows from.

Please always follow the requirements of the Thermory cladding installation and maintenance guide.

## MAINTENANCE

Natural uncoated thermally modified wood does not require any special care other than cleaning. Thermory's thermally modified cladding boards are durable and remain weatherproof for decades, even in the most demanding climates.

Thermally modified wood can be washed with water. When rinsing, it's a good idea to use a garden hose with a spray nozzle on a low-pressure setting, testing it on a small area prior to beginning. A strong jet of water can damage the wood, resulting in an uneven appearance.

Before carrying out any maintenance painting, read Thermory's cladding maintenance guide.

## PLEASE CONSIDER THE FOLLOWING

Keep in mind that wood is a natural material, and so each board ages in its own way. Different sides of a building's façade will also age differently depending on the amount of sun and rain they're exposed to.

Surface cracks appear within a month of installation and are more visible in drier weather. The gaps will slowly develop and increase in size throughout the lifetime of the cladding, but this will not prevent it from being usable.

THERMORY CLADDING  
INSTALLATION GUIDE



THERMORY CLADDING  
MAINTENANCE GUIDE















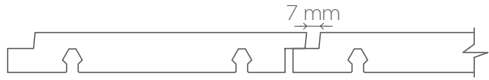



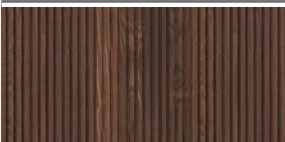



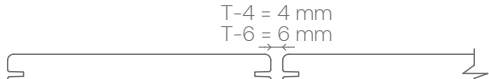

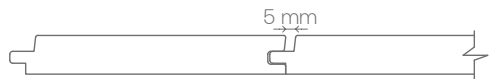

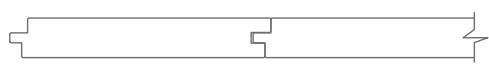

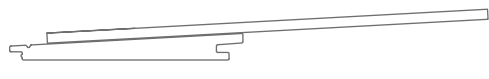

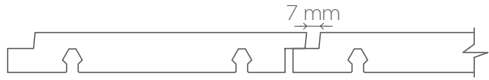



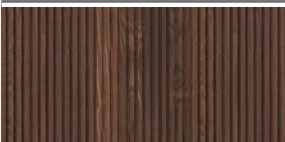



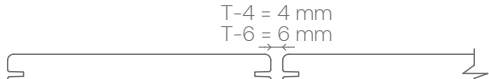

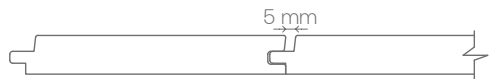

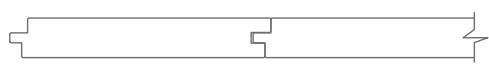

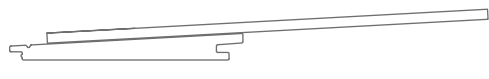



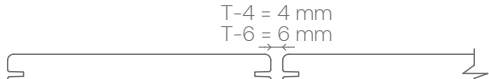

# Standard assortment

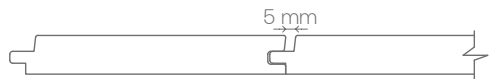
Minimum order quantity per item starting from 1 bundle, ask for length availability.

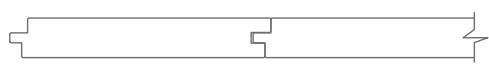
## Thermo-ash

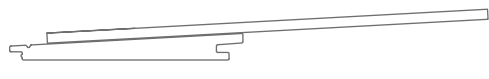
(PAGE 6) (PAGE 6)

WOOD SPECIES	QUALITY	THICKNESS, MM	WIDTH, MM	COVERING WIDTH, MM	PROFILE	TEXTURE PICTURE																																																																																				
Thermo-ash	Select	20	52	57.1	<b>C7J</b> 																																																																																					
			72	80			Thermo-ash	Select	20	52	57.1	<b>C4J</b> 		Thermo-ash	Select	20	150	143.2	<b>C23J</b> 		Thermo-ash	Select	20	132	121	<b>C6</b> 		Thermo-ash	Select	26	91	81	<b>C72</b> 		118	108	Thermo-ash	Select	20	72	53	<b>C34 Mix&amp;Match</b> 		95	76	132	113	Thermo-ash	Select	20	95	95	<b>D4</b> 		132	132	150	150	42	90	Thermo-ash	Select	20	95	101	<b>D4 sg2</b> 		132	138	150	156	Thermo-ash	Select	20	132	124	<b>C20</b> 		Thermo-ash	Select	20	132	123	<b>CAR7</b> 		Thermo-ash	Select	39 x 379 x 1250 mm		<b>Shingle panel S3-E - "Even"</b> 
Thermo-ash	Select	20	52	57.1	<b>C4J</b> 																																																																																					
Thermo-ash	Select	20	150	143.2	<b>C23J</b> 																																																																																					
Thermo-ash	Select	20	132	121	<b>C6</b> 																																																																																					
Thermo-ash	Select	26	91	81	<b>C72</b> 																																																																																					
			118	108			Thermo-ash	Select	20	72	53	<b>C34 Mix&amp;Match</b> 		95	76	132	113	Thermo-ash	Select	20	95	95	<b>D4</b> 		132	132	150	150	42	90	Thermo-ash	Select	20	95	101	<b>D4 sg2</b> 		132	138	150	156	Thermo-ash	Select	20	132	124	<b>C20</b> 		Thermo-ash	Select	20	132	123	<b>CAR7</b> 		Thermo-ash	Select	39 x 379 x 1250 mm		<b>Shingle panel S3-E - "Even"</b> 				(useful width 165 mm; useful coverage for 1 panel is 0.206m²)																										
Thermo-ash	Select	20	72	53	<b>C34 Mix&amp;Match</b> 																																																																																					
			95	76																																																																																						
			132	113																																																																																						
Thermo-ash	Select	20	95	95	<b>D4</b> 																																																																																					
			132	132																																																																																						
			150	150																																																																																						
			42	90																																																																																						
Thermo-ash	Select	20	95	101	<b>D4 sg2</b> 																																																																																					
			132	138																																																																																						
			150	156																																																																																						
Thermo-ash	Select	20	132	124	<b>C20</b> 																																																																																					
Thermo-ash	Select	20	132	123	<b>CAR7</b> 																																																																																					
Thermo-ash	Select	39 x 379 x 1250 mm		<b>Shingle panel S3-E - "Even"</b> 																																																																																						
		(useful width 165 mm; useful coverage for 1 panel is 0.206m²)																																																																																								



\* ASK FOR LENGTH AVAILABILITY!

(PAGE 18)

(PAGES 8-9)



(PAGES 10-14)

(PAGES 15-16)

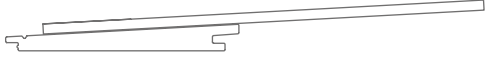

STANDARD LENGTHS (30 CM STEPS)*	END-MATCHING	FACE SIDE SURFACE OPTIONS	COLLECTIONS AND COATING OPTIONS	INSTALLATION METHOD	INSTALLATION ORIENTATION FOR EXTERIOR	PCS/BUNDLE	PCS/PACK
0.9-3.9 m	Yes	Planed or Brushed	Possible to order in Benchmark and Vivid Oiled collections	CLAD52/Alu Rail 52	Versatile (V+H)	8	560
				CLAD72/Alu Rail 72		4	420
0.9-3.9 m	Yes	Planed or Brushed	Possible to order in Benchmark and Vivid Oiled collections	CLAD52/Alu Rail 52	Versatile (V+H)	8	560
0.9-3.9 m	Yes	Planed or Brushed	Possible to order in Benchmark and Vivid Oiled collections	CLAD150/Alu Rail 150	Versatile (V+H)	4	196
0.9-3.9 m	Yes	Planed or Brushed	Possible to order in Benchmark and Vivid Oiled collections	B1-1 clip	Horizontal	4	224
0.9-3.9 m	Yes	Planed	Standalone profile, no coating or collection options available	Hidden screws, staples or nails	Vertical	3	432
							324
0.9-3.9 m	Yes	Planed or Brushed	Possible to order in Benchmark and Vivid Oiled collections	Hidden screws, staples or nails	Vertical	4	420
							308
							224
0.9-3.9 m	Yes	Planed or Brushed	Possible to order in Benchmark and Vivid Oiled collections	Visible screws, staples or nails	Versatile (V+H)	4	308
							224
							196
0.9-3.9 m	Yes	Planed or Brushed	Possible to order in Benchmark and Vivid Oiled collections	Visible screws, staples or nails	Versatile (V+H)	2	168
							308
0.9-3.9 m	Yes	Planed or Brushed	Possible to order in Benchmark and Vivid Oiled collections	T-4 clip	Versatile (V+H)	4	308
				T-6 clip			224
				T-6 clip			196
0.9-3.9 m	Yes	Planed or Brushed	Possible to order in Benchmark and Vivid Oiled collections	Visible screws, staples or nails	Versatile (V+H)	4	196
0.9-3.9 m	Yes	Planed or Brushed	Possible to order in Benchmark and Vivid Oiled collections	Visible screws, staples or nails	Versatile (V+H)	4	196
1.25 m	No	Roughened	Can be finished on site with Vivid Oiled collection coatings	Hidden screws, staples or nails	Vertical	1	76

(PAGE 6)







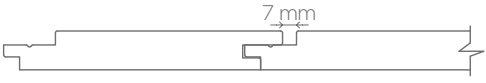
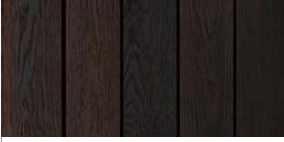

(PAGE 6)

WOOD SPECIES	QUALITY	THICKNESS, MM	WIDTH, MM	COVERING WIDTH, MM	PROFILE	TEXTURE PICTURE
Thermo-ash	Select	39 x 379 x 1250 mm (useful width 165 mm; useful coverage for 1 panel is 0.206m <sup>2</sup> )			Shingle panel S3-S – “Staggered” 	

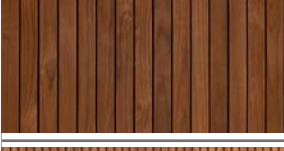
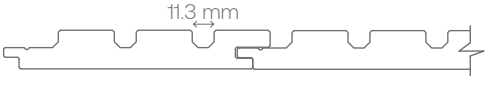
## Thermo-oak

Thermo-oak	Character	20	52	57.1	C4J 	
Thermo-oak	Character	20	150	131	C34 	

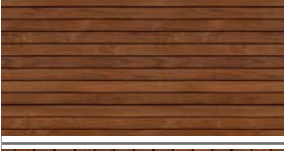
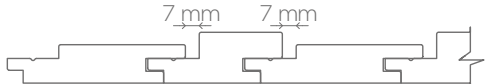
## Thermo-radiata pine

Thermo-radiata pine	Clear	20	65	71.4	C7J 	
Thermo-radiata pine	Clear	20	65	71.4	C4J 	
Thermo-radiata pine	Clear	20	138	120	CAR3G 	
Thermo-radiata pine	Clear	20	138	130	C3 	
Thermo-radiata pine	Clear	20	138	138	C4 	
Thermo-radiata pine	Clear	20	138	119	C34 Mix & Match 	
			115	96		
		42	65	46		



\* ASK FOR LENGTH  
AVAILABILITY!

(PAGE 18)

(PAGES 8-9)

(PAGES 10-14)

(PAGES 15-16)











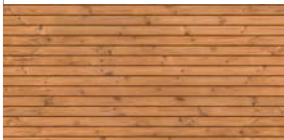

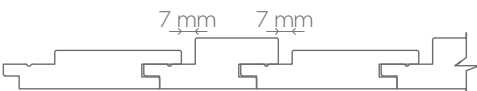

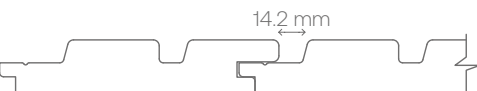
STANDARD LENGTHS (30 CM STEPS)*	END-MATCHING	FACE SIDE SURFACE OPTIONS	COLLECTIONS AND COATING OPTIONS	INSTALLATION METHOD	INSTALLATION ORIENTATION FOR EXTERIOR	PCS/BUNDLE	PCS/PACK
1.25 m	No	Roughened	Can be finished on site with Vivid Oiled collection coatings	Hidden screws, staples or nails	Vertical	1	76
0.9-3.9 m	Yes	Brushed	Possible to order in Vivid Oiled (dark oil)	CLAD52/Alu Rail 52	Versatile (V+H)	8	560
0.9-3.9 m	Yes	Brushed	Possible to order in Vivid Oiled (dark oil)	Hidden screws, staples or nails	Vertical	4	196
3-5.4 m	Yes	Planed or Brushed	Possible to order in Benchmark and Vivid (Translucent, Opaque, Oiled) collections	CLAD65/Alu Rail 65	Versatile (V+H)	8	448
3-5.4 m	Yes	Planed or Brushed	Possible to order in Benchmark and Vivid (Translucent, Opaque, Oiled) collections	CLAD65/Alu Rail 65	Vertical	8	448
3-5.4 m	Yes	Planed or Brushed	Possible to order in Benchmark and Vivid (Translucent, Opaque, Oiled) collections	Hidden screws, staples or nails	Vertical	4	256
3-5.4 m	Yes	Planed or Brushed	Possible to order in Benchmark and Vivid (Translucent, Opaque, Oiled) collections	Visible screws, staples or nails	Versatile (V+H)	4	256
3-5.4 m	Yes	Planed or Brushed	Possible to order in Benchmark and Vivid (Translucent, Opaque, Oiled) collections	Visible screws, staples or nails	Versatile (V+H)	4	256
3-5.4 m	Yes	Planed or Brushed	Possible to order in Benchmark and Vivid (Translucent, Opaque, Oiled) collections	Hidden screws, staples or nails	Vertical	4	256
							288
	No						256

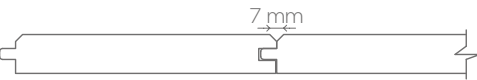
(PAGE 6)

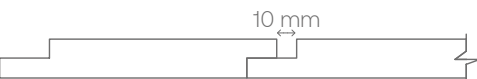

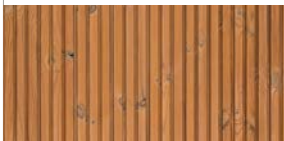
(PAGE 6)

WOOD SPECIES	QUALITY	THICKNESS, MM	WIDTH, MM	COVERING WIDTH, MM	PROFILE	TEXTURE PICTURE
--------------	---------	---------------	-----------	--------------------	---------	-----------------

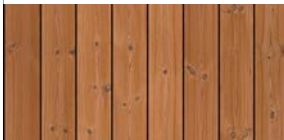
**Thermo-pine**

Thermo-pine	A	20	67	67	<b>C7</b> 	
		26	68	68		
Thermo-pine	A	20	65	71.4	<b>C7J</b> 	
Thermo-pine	A	20	68	49	<b>C34 Mix &amp; Match</b> 	
			90	71		
			115	96		
		26	68	49		
			90	71		
			115	96		
42	68	49				
90	71					
Thermo-pine	A	26	140	120	<b>C8G</b> 	
Thermo-pine	A	20	140	132	<b>C3</b> 	
Thermo-pine	A	20	115	100	<b>UYS10</b> 	
			140	125		
Thermo-pine	A	32	140	126	<b>C65</b> 	
Thermo-pine	A	42	42	42	<b>D4</b> 	
Thermo-pine	A	42	140	140	<b>D4</b> 	

**Thermo-spruce**

Thermo-spruce	AB	20	68	68	<b>C4B</b> 	
			140	140		
			186	186		



\* ASK FOR LENGTH AVAILABILITY!

(PAGE 18)











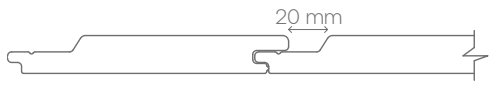

(PAGES 8-9)

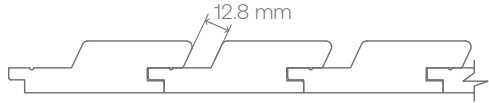
(PAGES 10-14)



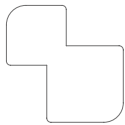

(PAGES 15-16)

STANDARD LENGTHS (30 CM STEPS)*	END-MATCHING	FACE SIDE SURFACE OPTIONS	COLLECTIONS AND COATING OPTIONS	INSTALLATION METHOD	INSTALLATION ORIENTATION FOR EXTERIOR	PCS/BUNDLE	PCS/PACK
3-5.4 m	Yes	Planed or Brushed	Possible to order in Benchmark and Vivid (Silvered, Translucent, Opaque, Oiled) collections	Visible screws, staples or nails	Versatile (V+H)	8	512
						6	432
3-5.4 m	Yes	Planed or Brushed	Possible to order in Benchmark and Vivid (Silvered, Translucent, Opaque, Oiled) collections	CLAD65/Alu Rail 65	Versatile (V+H)	8	448
3-5.4 m	Yes	Planed or Brushed	Possible to order in Benchmark and Vivid (Silvered, Translucent, Opaque, Oiled) collections	Hidden screws, staples or nails	Vertical	8	512
						4	384
						6	288
						3	432
						3	324
						4	243
3-5.4 m	No	Planed or Brushed	Possible to order in Benchmark and Vivid (Silvered, Translucent, Opaque, Oiled) collections	Hidden screws, staples or nails	Versatile (V+H)	4	256
						2	192
3-5.4 m	No	Planed or Brushed	Possible to order in Benchmark and Vivid (Silvered, Translucent, Opaque, Oiled) collections	Hidden screws, staples or nails	Versatile (V+H)	3	216
3-5.4 m	Yes	Planed or Brushed	Possible to order in Benchmark and Vivid (Silvered, Translucent, Opaque, Oiled) collections	Visible screws, staples or nails	Versatile (V+H)	4	256
3-5.4 m	Yes	Planed or Brushed	Possible to order in Benchmark and Vivid (Silvered, Translucent, Opaque, Oiled) collections	Visible screws, staples or nails	Vertical	4	256
						4	288
3-5.4 m	No	Planed or Brushed	Standalone profile, no coating or collection options available	Hidden screws, staples or nails	Vertical	3	168
3-5.4 m	No	Planed or Brushed	Possible to order in Benchmark and Vivid (Silvered, Translucent, Opaque, Oiled) collections	Visible screws, staples or nails	Vertical	4	384
3-5.4 m	No	Planed or Brushed	Possible to order in Benchmark and Vivid (Silvered, Translucent, Opaque, Oiled) collections	Visible screws, staples or nails	Vertical	2	128
3-5.4 m	Yes	Roughened or Brushed	Possible to order in Benchmark and Vivid (Silvered, Translucent, Opaque, Oiled) collections	Visible screws, staples or nails	Vertical	8	512
						4	256
							160

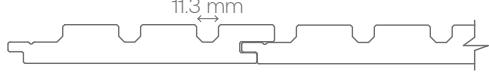

(PAGE 6) (PAGE 6)

WOOD SPECIES	QUALITY	THICKNESS, MM	WIDTH, MM	COVERING WIDTH, MM	PROFILE	TEXTURE PICTURE
Thermospruce	AB	19	141	124	<b>C26</b> 	
			186	169		
Thermospruce	AB	21	185	165	<b>C11-S</b> 	
Thermospruce	AB	26	92	73	<b>C54G</b> 	
Thermospruce	AB	20	186	175	<b>C15</b> 	
Thermospruce	AB	20	140	132	<b>C24</b> 	
Thermospruce	AB	42	42		<b>CP3</b> 	

### Stripes

Thermoradiata pine	Clear	19	138	120	<b>CAR3G</b> 	
Thermopine	A	25	140	120	<b>C8G</b> 	

### Ignite

Thermospruce	AB	20	186	175	<b>C15</b> 	
--------------	----	----	-----	-----	--	---



\* ASK FOR LENGTH AVAILABILITY!

(PAGE 18)

(PAGES 8-9)

(PAGES 10-14)

(PAGES 15-16)

STANDARD LENGTHS (30 CM STEPS)*	END-MATCHING	FACE SIDE SURFACE OPTIONS	COLLECTIONS AND COATING OPTIONS	INSTALLATION METHOD	INSTALLATION ORIENTATION FOR EXTERIOR	PCS/BUNDLE	PCS/PACK
3-5.4 m	Yes	Roughened or Brushed	Possible to order in Benchmark and Vivid (Silvered, Translucent, Opaque, Oiled) collections	Hidden screws, staples or nails	Versatile (V+H)	4	256 192
3-5.4 m	No	Roughened	Possible to order in Benchmark and Vivid (Silvered, Translucent, Opaque, Oiled) collections	Hidden screws, staples or nails	Versatile (V+H)	4	192
3-5.4 m	Yes	Roughened	Possible to order in Stripes and Vivid (Silvered, Translucent, Opaque, Oiled) collections	Hidden screws, staples or nails	Versatile (V+H)	3	324
3-5.4 m	Yes	Brushed or Embossed (Ignite or Dune)	Possible to order in Benchmark, Kodiak, Ignite, Dune and Vivid (Silvered, Translucent, Opaque, Oiled) collections	Visible screws, staples or nails	Versatile (V+H)	4	192
3-5.4 m	Yes	Brushed or Embossed (Ignite or Dune)	Possible to order in Benchmark, Ignite, Dune and Vivid (Silvered, Translucent, Opaque, Oiled) collections	Visible screws, staples or nails	Versatile (V+H)	4	256
4.2-4.8 m	No	Planed	Standalone profile, no coating or collection options available	Visible screws, staples or nails	Vertical	1	200
3-5.4 m	No	Planed	Possible to order in Stripes collection, recommended for interior use	Hidden screws, staples or nails	Vertical	4	256
3-5.4 m	No	Planed	Possible to order in Stripes collection, recommended for interior use	Hidden screws, staples or nails	Versatile (V+H)	3	216
3-5.4 m	Yes	Ignite, pressed pattern	Possible to order in Ignite (Ignite 5, semi-transparent) collection	Visible screws, staples or nails	Versatile (V+H)	4	192

THERMO-ASH



Thermory thermo-ash cladding C7J. Disney Store Shanghai China. Gensler Architects.



Thermory thermo-ash cladding. Private house in USA. OPAL Architecture. Trent Bell Photography

THERMO-OAK



Thermory thermo-oak cladding C57. TNAH Las Vegas Nevada.



Thermory thermo-oak C57 wall cladding

THERMO-PINE



Thermory thermo-pine cladding. Powerhouse Telemark in Norway. Distributor: Moelven.Architects: Snøhetta. Photo Jeanett Teigen



Thermory thermo-pine cladding C7J. AARhus residential development. Distributor: Dolle Nordic.Architect: Bjarke Ingels Group. Photo Kåre Viemose



**THERMO-RADIATA PINE**



Thermory thermo radiata pine cladding. Kiikri residential development in Estonia. Photo Allan Leppikson



Thermory thermo radiata pine cladding. Architect: PVL Architecten. Distributor Carpentier.

**THERMO-SPRUCE**



Thermory thermo-spruce Kodiak cladding C15. Private residence in Jose Ignacio. Photo Maximiliano Vilella

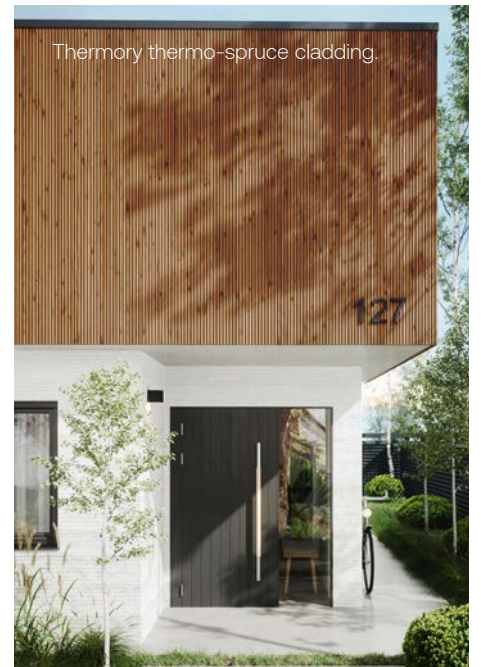





Thermory thermo-spruce cladding.





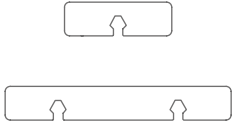

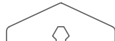
# Made-to-order assortment

Minimum order quantity per item for thermo-ash, thermo-oak and thermo-radiata pine: 3,000 running meters.  
 Minimum order quantity per item for thermo-pine and thermo-spruce: 5,000 running meters or more.



## Grad® installation system

PROFILE	WOOD SPECIES	THICKNESS, MM	WIDTH, MM	COVERING WIDTH, MM	STANDARD LENGTHS (30 CM STEPS)*	END-MATCHING	INSTALL. METHOD	INSTALL. ORIENT. FOR EXTERIOR	
<b>C4J</b>  	Thermo-ash	20	52	57.1	0.9–3.9 m	Yes	CLAD52/Alu Rail 52	Vertical	
		26							
		42	42						
	Thermo-oak	20	52	71.4	3–5.4 m	CLAD65/Alu Rail 65			
		Thermo-radiata pine	20				65		71.4
	Thermo-pine		20	42	57.1	0.9–2.7 m	CLAD52/Alu Rail 52		
		Thermo-spruce	20	65	71.4	3–5.4 m	CLAD65/Alu Rail 65		
	42		42	57.1	No				CLAD52/Alu Rail 52
	<b>C7J</b>  	Thermo-ash	20	52	57.1	0.9–3.9 m	Yes		CLAD52/Alu Rail 52
			26	52	57.1				CLAD72/Alu Rail 72
Thermo-radiata pine			20	65	71.4			3–5.4 m	CLAD65/Alu Rail 65
		Thermo-pine	20	65		CLAD65/Alu Rail 65			
26			68						
Thermo-spruce		20	65	CLAD65/Alu Rail 65					
		20	65						
<b>C23J</b>  		Thermo-ash	20	150	143.2	0.9–3.9 m	Yes	CLAD150/Alu Rail 150	
		Thermo-radiata pine		138	131.2	3–5.4 m		CLAD138	
		Thermo-pine		138					
	Thermo-spruce	138							
<b>C80J</b>  	Thermo-pine	26	65	68	3–5.4 m	No	Grad clip	Versatile (V+H)	
	Thermo-spruce								
<b>C81J</b>  	Thermo-pine	26	65	68	3–5.4 m	No	Grad clip	Vertical	
	Thermo-spruce								



PROFILE	WOOD SPECIES	THICKNESS, MM	WIDTH, MM	COVERING WIDTH, MM	STANDARD LENGTHS (30 CM STEPS)*	END-MATCHING	INSTALL. METHOD	INSTALL. ORIENT. FOR EXTERIOR
C82J 	Thermopine	26	65	68	3-5.4 m	No	Grad clip	Vertical
	Thermospruce							
C83J 	Thermopine	20	68	60	3-5.4 m	No	Grad clip	Versatile (V+H)
	Thermospruce							
CAR10J 	Thermopine	26	140	131	3-5.4 m	No	Grad clip	Versatile (V+H)
	Thermospruce							
D45J 	Thermoash	21	118	123	0.9-3.9 m	No	Grad strip	Vertical
	Thermopine	26			3-5.4 m			

**B1-1 clip**









C6 	Thermoash	20	132	121	0.9-3.9 m	Yes	B1-1 clip	Horizontal
			155	144				
	Thermoradiata pine		115	104	3-5.4 m			
			138	127				
	Thermopine		115	104				
			140	129				
C9 	Thermoash	20	95	98	0.9-3.9 m	Yes	B1-1 clip	Horizontal
		112	115					
		132	135					

**T-4 and T-6 clip**

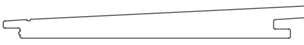
D4 sg2 	Thermoash	20	95	99	0.9-3.9 m	Yes	T-4 clip	Versatile (V+H)
			112	116				
			132	138				
			150	156				
							T-6 clip	





PROFILE	WOOD SPECIES	THICKNESS, MM	WIDTH, MM	COVERING WIDTH, MM	STANDARD LENGTHS (30 CM STEPS)*	END-MATCHING	INSTALL. METHOD	INSTALL. ORIENT. FOR EXTERIOR
---------	--------------	---------------	-----------	--------------------	---------------------------------	--------------	-----------------	-------------------------------

**Installation with screws, nails or staples – hidden fixing**





<p>C8G</p> 	Thermo-radiata pine	20	115	95	3–5.4 m	Yes	Hidden screws, staples or nails	Versatile (V+H)
			140	120				
	Thermo-pine	26	115	95				
			140	120				
	Thermo-spruce		140	140				
<p>C8D</p> 	Thermo-pine	26	140	119	3–5.4 m	Yes	Dekora clip or hidden screws, staples or nails	Versatile (V+H)
<p>C11-S</p> 	Thermo-pine	21	140	120	3–5.4 m	No	Hidden screws, staples or nails	Horizontal
	Thermo-spruce		185	165				
<p>C25</p> 	Thermo-radiata pine	20	138	121	3–5.4 m	Yes	Hidden screws, staples or nails	Vertical
			185	168				
	Thermo-pine		140	123				
	Thermo-spruce		140	123				
			185	168				
<p>C26</p> 	Thermo-radiata pine	19	140	123	3–5.4 m	Yes	Hidden screws, staples or nails	Versatile (V+H)
			185	168				
	Thermo-spruce		141	124				
			92	75				
			186	169				
<p>C30</p> 	Thermo-ash	20	118	101	0.9 – 3.9 m	No	Hidden screws, staples or nails	Versatile (V+H)
			92	75	3–5.4 m			
	Thermo-pine		118	101				
<p>CAR3G</p> 	Thermo-radiata pine	20	138	121	3–5.4 m	Yes	Hidden screws, staples or nails	Vertical
<p>C32G</p> 	Thermo-radiata pine	20	140	123	3–5.4 m	Yes	Hidden screws, staples or nails	Versatile (V+H)
	Thermo-pine							
	Thermo-spruce							













PROFILE	WOOD SPECIES	THICKNESS, MM	WIDTH, MM	COVERING WIDTH, MM	STANDARD LENGTHS (30 CM STEPS)*	END-MATCHING	INSTALL. METHOD	INSTALL. ORIENT. FOR EXTERIOR				
C34 Mix & Match  	Thermo-ash	20	72	53	0.9-3.9 m	Yes	Hidden screws, staples or nails	Vertical				
			95	76								
			132	113								
			150	131								
		26	90	71								
			115	96								
	42	65	46	3-5.4 m		Yes						
		Thermo-radiata pine	20						115	96	Yes	
	138		119						No			
	42	65	46						3-5.4 m	No		
		Thermo-pine	20								68	49
	90		71									
	115	96	3-5.4 m	No								
		140			121							
	26	68			49	3-5.4 m	Yes					
		90			71							
	115	96			3-5.4 m			No				
		Thermo-spruce							20	68	49	Yes
	90		71									
	42	68	49	3-5.4 m					No			
Thermo-spruce		26	68			49	Yes					
	90	71										
42	68	49	3-5.4 m		No							
	Thermo-radiata pine	20				140		121		No		
Thermo-pine		20				140		121			Hidden screws, staples or nails	
	Thermo-spruce	26		68		49		Vertical				
90		71										
42	68	49		3-5.4 m		No						
	Thermo-spruce	26	68		49		Hidden screws, staples or nails					
Thermo-ash		26	90		71				Yes			
	Thermo-pine	26	92		73					Hidden screws, staples or nails		
Thermo-spruce		26	92		73			Versatile (V+H)				











PROFILE	WOOD SPECIES	THICKNESS, MM	WIDTH, MM	COVERING WIDTH, MM	STANDARD LENGTHS (30 CM STEPS)*	END-MATCHING	INSTALL. METHOD	INSTALL. ORIENT. FOR EXTERIOR
C65 	Thermo-pine	32	140	126	3–5.4 m	No	Hidden screws, staples or nails	Vertical
C72 	Thermo-ash	26	91	81	0.9–3.9 m	Yes	Hidden screws, staples or nails	Vertical
	Thermo-radiata pine		118	108				
C75 	Thermo-spruce	26	135	125	3–5.4 m	Yes	Hidden screws, staples or nails	Vertical
			185	175				
Wave-2 	Thermo-pine	26	68	49	3–5.4 m	No	Hidden screws, staples or nails	Versatile (V+H)

**Installation with screws, nails or staples – visible fixing**

C1 	Thermo-radiata pine	20	138	130	3–5.4 m	Yes	Visible screws, staples or nails	Versatile (V+H)
	Thermo-pine		115	107				
	Thermo-spruce		115	107				
			140	132				
C3 	Thermo-radiata pine	20	115	107	3–5.4 m	Yes	Visible screws, staples or nails	Versatile (V+H)
			138	130				
	Thermo-pine		115	107				
C15 	Thermo-pine	20	140	129	3–5.4 m	Yes	Visible screws, staples or nails	Versatile (V+H)
	Thermo-spruce		186	175				
C17 	Thermo-pine	26	140	129	3–5.4 m	No	Visible screws, staples or nails	Vertical
	Thermo-spruce							



PROFILE	WOOD SPECIES	THICKNESS, MM	WIDTH, MM	COVERING WIDTH, MM	STANDARD LENGTHS (30 CM STEPS)*	END-MATCHING	INSTALL. METHOD	INSTALL. ORIENT. FOR EXTERIOR
<b>C20</b>  	Thermo-ash	20	95	87	0.9–3.9 m	Yes	Visible screws, staples or nails	Versatile (V+H)
			112	104				
			132	124				
			150	142				
	Thermo-oak		132	124				
			150	142				
<b>C24</b>  	Thermo-spruce	20	140	132	3–5.4 m	Yes	Visible screws, staples or nails	Versatile (V+H)
			186	178				
	Thermo-pine		115	107				
			140	132				
<b>C32</b>  	Thermo-radiata pine	20	140	129	3–5.4 m	Yes	Visible screws, staples or nails	Versatile (V+H)
	Thermo-pine							
	Thermo-spruce							
<b>C47</b>  	Thermo-pine	26	90	82	3–5.4 m	No	Visible screws, staples or nails	Vertical
<b>C56–471</b>  	Thermo-pine	21	92	82	3–5.4 m	Yes	Visible screws, staples or nails	Versatile (V+H)
			118	108				
			142	132				
<b>C57</b>  	Thermo-oak	20	132	124	0.9–3.9 m	Yes	Visible screws, staples or nails	Versatile (V+H)
			150	142				
<b>C62N</b>  	Thermo-spruce	20	140	129	3–5.4 m	Yes	Visible screws, staples or nails	Versatile (V+H)
			185	174				
<b>C62N–G12</b>  	Thermo-spruce	20	140	129	3–5.4 m	Yes	Visible screws, staples or nails	Versatile (V+H)
<b>C87</b>  	Thermo-radiata pine	20	138	128	3–5.4 m	Yes	Visible screws, staples or nails	Versatile (V+H)
	Thermo-pine							
<b>CAR3</b>  	Thermo-radiata pine	20	138	130	3–5.4 m	No	Visible screws, staples or nails	Vertical
	Thermo-oak		132	126	0.9–3.9 m			





PROFILE	WOOD SPECIES	THICKNESS, MM	WIDTH, MM	COVERING WIDTH, MM	STANDARD LENGTHS (30 CM STEPS)*	END-MATCHING	INSTALL. METHOD	INSTALL. ORIENT. FOR EXTERIOR	
CAR7 	Thermo-ash	20	132	123	0.9–3.9 m	Yes	Visible screws, staples or nails	Versatile (V+H)	
CAR8 	Thermopine	26	130	122	3–5.4 m	No	Visible screws, staples or nails	Versatile (V+H)	
	Thermo-ash				0.9–3.9 m				
CAR10 	Thermopine	26	140	131	3–5.4 m	No	Visible screws, staples or nails	Versatile (V+H)	
	Thermospruce								
CAR12 	Thermo-ash	20	155	146	0.9–3.9 m	Yes	Visible screws, staples or nails	Versatile (V+H)	
CDF 	Thermopine	20	140	125	3–5.4 m	Yes	Visible screws, staples or nails	Versatile (V+H)	
CDF–Barn 	Thermopine	20	140	125	3–5.4 m	Yes	Visible screws, staples or nails	Versatile (V+H)	
Z – Mix & Match 	Thermopine	20	66	60	3–5.4 m	Yes	Visible screws, staples or nails	Vertical	
			115	109					
			140	134					
			26	68					62
			115	109					
			140	134					
UTS10–G10 	Thermo-ash	20	132	122	0.9–3.9 m	Yes	Visible screws, staples or nails	Vertical	
	Thermopine		138	128	3–5.4 m				
			115	105					
			140	130					
UYS10 	Thermopine	20	92	77	3–5.4 m	Yes	Visible screws, staples or nails	Vertical	
			115	100					
			140	125					
UYS10–G10 	Thermopine	20	140	125	3–5.4 m	Yes	Visible screws, staples or nails	Vertical	

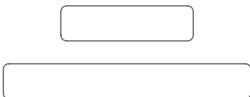

PROFILE	WOOD SPECIES	THICKNESS, MM	WIDTH, MM	COVERING WIDTH, MM	STANDARD LENGTHS (30 CM STEPS)*	END-MATCHING	INSTALL. METHOD	INSTALL. ORIENT. FOR EXTERIOR
UYV 	Thermo-pine	20	140	129	3-5.4 m	Yes	Visible screws, staples or nails	Versatile (V+H)

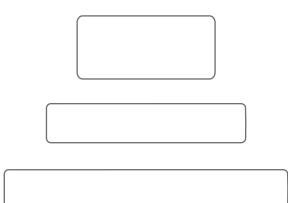
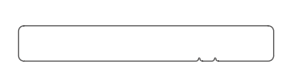
**Installation with screws, nails or staples – boards and battens**

C4 	Thermo-ash	20	52	52	0.9-3.9 m	Yes	Visible screws, staples or nails	Vertical
			72	72				
		26	52	52				
			90	90				
			115	115				
			130	130				
			145	145				
			160	160				
	42	42	42					
		90	90					
	Thermo-oak	20	52	52	0.9-3.9 m	Yes	Visible screws, staples or nails	Vertical
			65	65				
	Thermo-radiata pine	20	115	115	3-5.4 m	No	Visible screws, staples or nails	Vertical
			138	138				
			185	185				
		42	42	42				
			90	90				
			140	140				
	Thermo-pine	20	67	67	3-5.4 m	No	Visible screws, staples or nails	Vertical
			90	90				
115			115					
140		140						
26		68	68					
Thermo-spruce	42	42	42	No	No			

PROFILE	WOOD SPECIES	THICKNESS, MM	WIDTH, MM	COVERING WIDTH, MM	STANDARD LENGTHS (30 CM STEPS)*	END-MATCHING	INSTALL. METHOD	INSTALL. ORIENT. FOR EXTERIOR	
<p>D4</p> 	Thermo-ash	20	95	95	0.9–3.9 m	Yes	Visible screws, staples or nails	Vertical	
			112	112					
			132	132					
			150	150					
			190	190					
	Thermo-oak	20	95	95	0.9–3.9 m	Yes			
			118	118					
			132	132					
			150	150					
			26	90					90
				118					118
	130	130							
	Thermo-pine	26	145	145	3–5.4 m	Yes			
			160	160					
			90	90					
	Thermo-pine	42	115	115	3–5.4 m	No			
			140	140					
			68	68					
Thermo-spruce	42	90	90	3–5.4 m	No				
		140	140						
<p>C4B</p> 	Thermo-spruce	20	68	68	3–5.4 m	Yes			
			140	140					
			186	186					
		26	68	68					
<p>D4B</p> 	Thermo-spruce	26	140	140	3–5.4 m	Yes			
			185	185					
<p>C7</p> 	Thermo-ash	20	52	52	0.9–3.9 m	Yes	Visible screws, staples or nails	Versatile (V+H)	
	Thermo-pine		90	90	3–5.4 m				
		26	68	68					
<p>C7B</p> 	Thermo-spruce	20	67	67	3–5.4 m	Yes	Visible screws, staples or nails	Versatile (V+H)	



PROFILE	WOOD SPECIES	THICKNESS, MM	WIDTH, MM	COVERING WIDTH, MM	STANDARD LENGTHS (30 CM STEPS)*	END-MATCHING	INSTALL. METHOD	INSTALL. ORIENT. FOR EXTERIOR
---------	--------------	---------------	-----------	--------------------	---------------------------------	--------------	-----------------	-------------------------------

**Corner profiles – mouldings**

CP3		Thermo-spruce	42	42		3–5.4 m	No	Visible screws, staples or nails	Vertical
-----	---	---------------	----	----	--	---------	----	----------------------------------	----------

**Roofing**

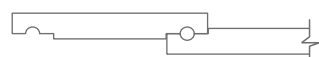
C10		Thermo-pine	20	140	139/81	3–5.4 m	No	Visible screws, staples or nails	Vertical
-----	--	-------------	----	-----	--------	---------	----	----------------------------------	----------

**Thermory Shingles**

PROFILE NAME	WOOD SPECIES	THICKNESS, MM	WIDTH, MM	COVERING WIDTH, MM	STANDARD LENGTHS (30 CM STEPS)*	END-MATCH.	INSTALL. METHOD	INSTALL. ORIENT. FOR EXTERIOR
S1 (Shingle)	Thermo-ash	7	70/90/110/125/130	50% of the length of the shingle (350 mm) = 175 mm	350 mm	No	Hidden screws, staples or nails	Vertical
Shingle panel S3E – “Even”		39 x 379 x 1250 mm (165 mm useful width)			1.25 m			
Shingle panel S3E – “Staggered”		39 x 379 x 1250 mm (165 mm useful width)						

Discover our wide range of wood species and profiles. Explore our product options on our website or ask your sales contact person.



# THERMORY Group companies



→ [www.thermory.com](http://www.thermory.com)

Sustainable and durable wood products: Natural and painted thermally modified cladding, thermally modified decking and flooring, sauna materials and products.



→ [www.auroomwellness.com](http://www.auroomwellness.com)

Auroom offers a customized range of high-quality, easy-to-install designer saunas, handcrafted from superior wood.

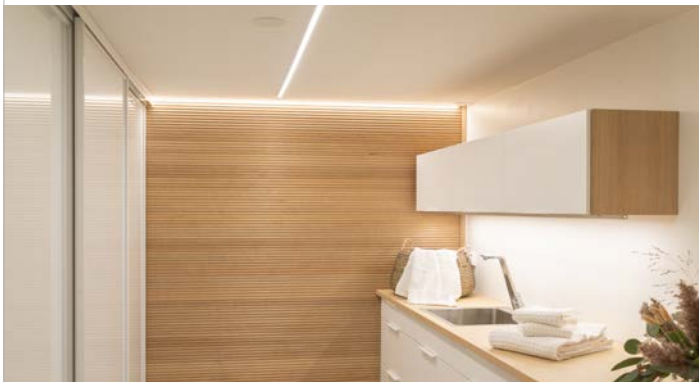

→ [www.siparila.fi](http://www.siparila.fi)

Modern Nordic exterior and interior solutions: Interior and exterior cladding, painted cladding, fire retardant cladding and wall paneling.

→ [thermory.com](http://thermory.com)

# Leave a lasting impact

THERMORY is a world leader in the thermal modification of wood. We offer high-quality, long-lasting solutions that benefit from environmentally friendly technology.

THERMORY promotes a transparent and responsible corporate culture. We care about the environment and treat nature with deep respect. Our purchasing process is environmentally responsible, and we exercise high standards for quality and sustainability. Our timber is carefully inspected and harvested from sustainably managed forests. If desired, we can offer PEFC, FSC® or Nordic Swan Ecolabel-certified wood.



As a renewable resource that is both durable and an excellent insulator, wood is one of the most environmentally friendly choices for your construction projects. We create lasting value, because we want to leave behind a more harmonious and sustainable world.

## REAL WOOD PRODUCTS WITH BEAUTY AND STABILITY IN EVERY FIBER

- DECKING
- CLADDING
- INTERIOR
- SAUNA



Thermory



Thermory



Thermorydesign



Thermory AS



Thermory's project 'Development of Resource-efficient Painted Thermally-modified Wood' is financed in cooperation with Enterprise Estonia (EAS) and the Norwegian Green ICT financing mechanism.

